

FEMALE SOCKET WELD END CONNECTOR

VALVE SERIES	STANDARD	DIAMETER A	DEPTH B	TAPER C
520	A.S.T.M. 1/2"	.848/.856"	.875"	0', 24'
	I.S.O. NW-15	20.1/20.3 MM	22.2 MM	0', 15'
	J.I.S. 16	21.9/22.3 MM	22.2 MM	0', 19'
521	A.S.T.M. 1"	1.325/1.335"	1.125"	0', 23'
	I.S.O. NW-25	32.1/32.3 MM	28.6 MM	0', 15'
	J.I.S. 25	31.9/32.4 MM	28.6 MM	0', 16'
524	A.S.T.M. 1-1/2"	1.912/1.924"	1.375"	0', 23'
	I.S.O. NW-40	50.1/50.3 MM	34.9 MM	0', 15'
	J.I.S. 40	47.9/48.5 MM	34.9 MM	0', 16'

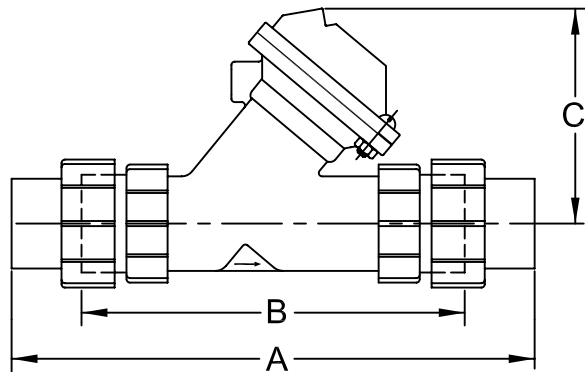

VALVE SERIES	UNITS	LENGTH A	LENGTH B	HEIGHT C
520	INCHES	7.00	4.87	2.62
	MM	177.8	123.7	66.5
521	INCHES	9.00	6.31	4.06
	MM	228.6	160.3	103.1
524	INCHES	12.50	9.31	5.06
	MM	317.5	23.5	128.5

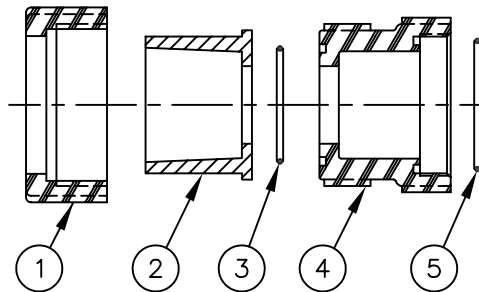

UNION END ADAPTOR

16605 Victor Rd
New Berlin, WI 53151
262-326-0100
www.aq-matic.com

AQ Matic Valve and Controls Company, Inc.

SERIES 520 UNION END ADAPTOR KITS

A.S.T.M. 1/2" INCLUDES ITEMS 1,2,3,4,5	E.P.D.M. O-RING	1070184	K520+100
	BUTYL O-RING	1070185	K520+101
	FKM O-RING	1070186	K520+102
I.S.O. NW-15 INCLUDES ITEMS 1,2,3,4,5	E.P.D.M. O-RING	1070190	K520+103
	BUTYL O-RING	1070191	K520+104
	FKM O-RING	1070192	K520+105
J.I.S. - 16 INCLUDES ITEMS 1,2,3,4,5	E.P.D.M. O-RING	1070193	K520+106
	BUTYL O-RING	1070194	K520+107
	FKM O-RING	1070195	K520+108

SERIES 521 UNION END ADAPTOR KITS

A.S.T.M. 1" INCLUDES ITEMS 1,2,3,4,5	E.P.D.M. O-RING	1070202	K521+100
	BUTYL O-RING	1070153	K521+101
	FKM O-RING	1070154	K521+102
I.S.O. NW-25 INCLUDES ITEMS 1,2,3,4,5	E.P.D.M. O-RING	1070204	K521+103
	BUTYL O-RING	1071155	K521+104
	FKM O-RING	1071156	K521+105
J.I.S. - 25 INCLUDES ITEMS 1,2,3,4,5	E.P.D.M. O-RING	1070205	K521+106
	BUTYL O-RING	1071157	K521+107
	FKM O-RING	1071158	K521+108

SERIES 524 UNION END ADAPTOR KITS

A.S.T.M. 1-1/2" INCLUDES ITEMS 1,2,3,4,5	E.P.D.M. O-RING	1070208	K524+100
	BUTYL O-RING	1071220	K524+101
	FKM O-RING	1070209	K524+102
I.S.O. NW-40 INCLUDES ITEMS 1,2,3,4,5	E.P.D.M. O-RING	1070212	K524+103
	BUTYL O-RING	1071221	K524+104
	FKM O-RING	1070213	K524+105
J.I.S. - 40 INCLUDES ITEMS 1,2,3,4,5	E.P.D.M. O-RING	1070214	K524+106
	BUTYL O-RING	1071222	K524+107
	FKM O-RING	1070215	K524+108

NOTE: ALL ADAPTOR KITS CONTAIN (2) ADAPTORS, (ONE KIT REQ'D PER VALVE)

NO.	DESCRIPTION	PART NO.
-----	-------------	----------

SERIES 520 UNION END ADAPTOR

1	TAILPIECE NUT	1074995	-520010K
2	FEMALE SOCKET WELD END CONNECTOR	A.S.T.M. 1/2"	1074991 -520007
		I.S.O. NW-15	1074992 -520008
		J.I.S. 16	1074993 -520009
3	O-RING	E.P.D.M.	1071730 -0RE-117
		BUTYL	1071766 -0RJ-117
		FKM	1071801 -0RV-117
4	TAILPIECE	1074996	-520011K
5	O-RING	E.P.D.M.	1071731 -0RE-120
		BUTYL	1071767 -0RJ-120
		FKM	1071802 -0RV-120

SERIES 521 UNION END ADAPTOR

1	TAILPIECE NUT	1075061	-521010K
2	FEMALE SOCKET WELD END CONNECTOR	A.S.T.M. 1"	1075061 -521007
		I.S.O. NW-25	1075063 -521008
		J.I.S. 25	1075065 -521009
3	O-RING	E.P.D.M.	1071732 -0RE-125
		BUTYL	1071768 -0RJ-125
		FKM	1071803 -0RV-125
4	TAILPIECE	1075068	-521011K
5	O-RING	E.P.D.M.	1071733 -0RE-128
		BUTYL	1071769 -0RJ-128
		FKM	1071804 -0RV-128

SERIES 524 UNION END ADAPTOR

1	TAILPIECE NUT	1075150	-524010K
2	FEMALE SOCKET WELD END CONNECTOR	A.S.T.M. 1 1/2"	1075144 -524007
		I.S.O. NW-40	1075146 -524008
		J.I.S. 40	1075148 -524009
3	O-RING	E.P.D.M.	1071735 -0RE-137
		BUTYL	1071771 -0RJ-137
		FKM	1071807 -0RV-137
4	TAILPIECE	1075151	-524011K
5	O-RING	E.P.D.M.	1071736 -0RE-138
		BUTYL	1071772 -0RJ-138
		FKM	1071808 -0RV-138

SEE FORM 1078152 FOR SOCKET WELD & FLANGED ADAPTORS

FORM NO. 1081309

A	RELEASE NEW DESIGN	1416	JWB	25JUL01	VP
REV	DESCRIPTION	ECO	DWN	DATE	APVD

AQ Matic
16605 West Victor Rd
New Berlin, WI 53151
262-326-0100
www.aq-matic.com

SERIES 520,521 & 524 DIAPHRAGM VALVE END CONNECTOR PARTS & KITS

SCALE	DRAWN	DATE	DWG. NO.
N/A	JWB	25JUL01	1078140

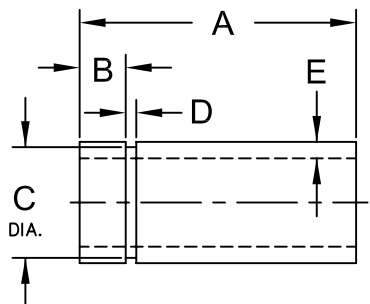

RING GROOVE DIMENSIONS

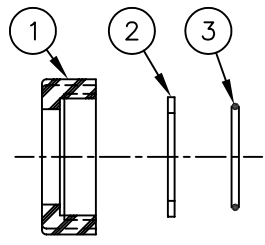

RETAINER NUT/SPLIT RING CONNECTOR

VALVE SERIES	UNITS	LENGTH A	LOCATION B	DIA. C	WIDTH D	WALL THK E
520	INCHES	2.25	0.500	0.730	0.115	0.147
	MM	57.2	12.7	18.5	2.9	3.7
521	INCHES	3.00	0.500	1.200	0.115	0.179
	MM	76.2	12.7	30.5	2.9	4.55
524	INCHES	4.00	0.875	1.800	0.115	0.200
	MM	57.2	22.2	45.7	2.9	5.1

VALVE SERIES	520	521	524
1 RETAINER NUT	1074974 -520-MK	1075041 -521-MK	1075112 -524-MK
2 SPLIT RING	1074975 -520-N	1075042 -521-N	1075113 -524-N
3 O-RING	E.P.D.M. 1071730 -OR-117	1071732 -OR-125	1071734 -OR-132
	BUTYL 1071766 -OR-117	1071768 -OR-125	1071770 -OR-132
	FKM 1071801 -OR-117	1071803 -OR-125	1071806 -OR-132

RETAINER NUT/SPLIT RING CONNECTOR KITS

SERIES 520 INCLUDES ITEMS 1,2,3	E.P.D.M. O-RING	1070238	K520109
	BUTYL O-RING	1070239	K520110
	FKM O-RING	1070240	K520111
SERIES 521 INCLUDES ITEMS 1,2,3	E.P.D.M. O-RING	1070244	K521109
	BUTYL O-RING	1071159	K521110
	FKM O-RING	1071160	K521111
SERIES 524 INCLUDES ITEMS 1,2,3	E.P.D.M. O-RING	1070246	K524109
	BUTYL O-RING	1071223	K524110
	FKM O-RING	1070247	K524111

NOTE: ALL CONNECTOR KITS CONTAIN (2) CONNECTORS, (ONE KIT REQ'D PER VALVE)

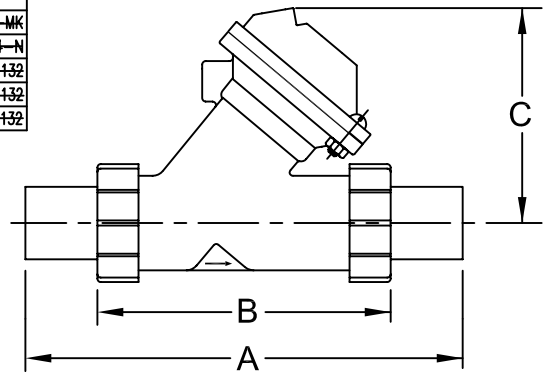

GROOVED ADAPTOR KITS

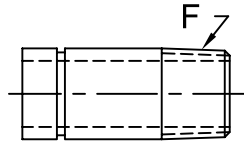

MALE PIPE THREAD

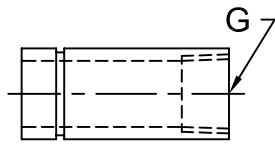

FEMALE PIPE THREAD

VALVE SERIES	520	521	524
PART NO.	1070221 K520-P	1070227 K521-P	1070233 K524-P
DIM. F	1/2" NPT	1" NPT	1-1/2" NPT

VALVE SERIES	520	521	524
PART NO.	1070222 K520-PA	1070228 K521-PA	1070234 K524-PA
DIM. G	3/8" NPT	3/4" NPT	1-1/4" NPT
			1-1/4" BSP

VALVE SERIES	UNITS	LENGTH A	LENGTH B	HEIGHT C
520	INCHES	7.00	3.93	2.62
	MM	177.8	99.8	66.5
521	INCHES	9.00	4.50	4.06
	MM	228.6	114.3	103.1
524	INCHES	13.25	7.75	5.06
	MM	336.5	196.9	128.5

SEE FORM 1078152 FOR SOCKET WELD & FLANGED ADAPTORS
FORM NO. 1081309

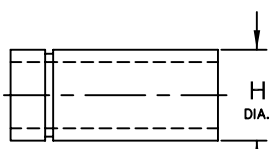

MALE SOCKET WELD

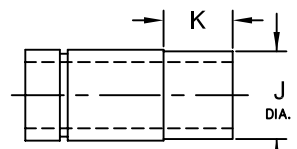

MALE SOCKET WELD (METRIC)

VALVE SERIES	520	521	524
PART NO.	1070220 K520-PG	1070226 K521-PG	1070232 K524-PG
DIM. H	0.840 IN. 21.3 MM	1.315 IN. 33.4 MM	1.900 IN. 48.3 MM

VALVE SERIES	520	521	524
PART NO.	1071057 K520-PE	1071091 K521-PE	1071162 K524-PE
DIM. J	20.2 MM	32.2 MM	50.2 MM
DIM. K	15.9 MM	25.4 MM	30.0 MM

NOTE: ALL ADAPTOR KITS CONTAIN (2) ADAPTORS, (ONE KIT REQ'D PER VALVE)

A	RELEASE NEW DESIGN	1416	JB	25JUL01	VP
REV	DESCRIPTION	ECO	DWN	DATE	APVD
		16605 West Victor Rd New Berlin, WI 53151 262-326-0100 www.aq-matic.com			
SERIES 520, 521 & 524 DIAPHRAGM VALVE END CONNECTOR PARTS & KITS					
SCALE	DRAWN	DATE	DWG. NO.		
N/A	JWB	25JUL01	1078140		